



GENUINE PARTS

INSTALLATION INSTRUCTIONS

DESCRIPTION:	Clear Rear Bumper Protector
APPLICATION:	Nissan Sentra (2013)
PART NUMBER:	999T6 LZ000

KIT CONTENTS:

Item	QTY	Part Description	Service Part Number
A	1	Clear Rear Bumper Film	N/A
B	1	Plastic Squeegee	N/A
C	1	Installation Instructions Replacement Template	999V2 AW000



A

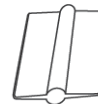

B



C

TOOLS REQUIRED:

- 90% Isopropyl Alcohol
- Dish Soap
- 32 Ounce Spray Bottle
- Water
- Soft Lint Free Micro fiber Cloth
- Air Release Tool

PRE-INSTALLATION WARNINGS, CAUTIONS, CRITICAL STEPS, and NOTES:

- Dealer Installation Recommended.
- **Application Solution:** Fill a 32 spray bottle with 25% isopropyl alcohol, 75% water, and add 5-7 drops of dish soap.
- Install in a non-dusty environment.
- Thoroughly wash vehicle with soap and water.
- Use tabs when handling film so no finger prints are left on adhesive.
- Install at ambient temperature of 65-90° F.

INSTALLATION PROCEDURE:

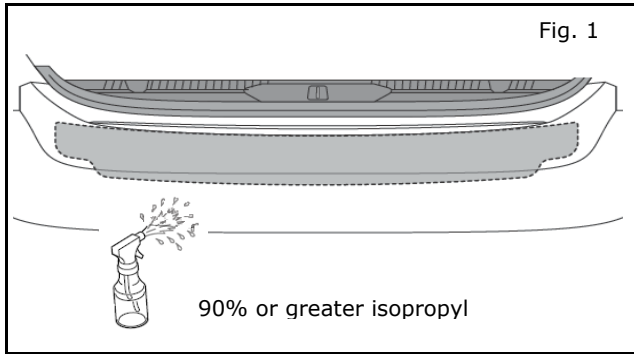

- 1) Using a clean lint free micro fiber cloth clean surface of rear bumper with 90% or greater isopropyl alcohol. Allow area to dry completely.

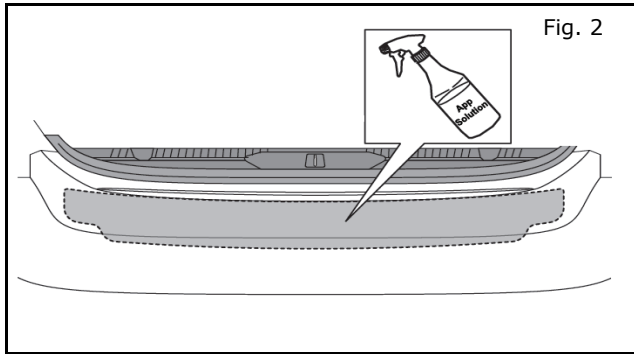

- 2) Spray bumper surface with application solution.

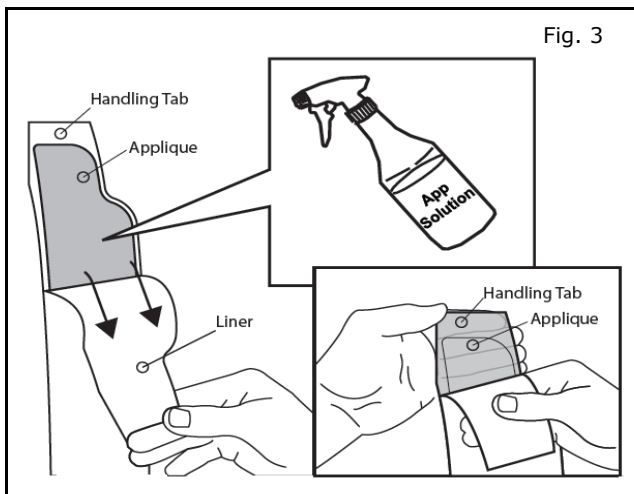

- 3) Hold part by handling tab and remove part liner.
- 4) Spray adhesive side with an even mist with application solution.

INSTALLATION PROCEDURE: (continued)

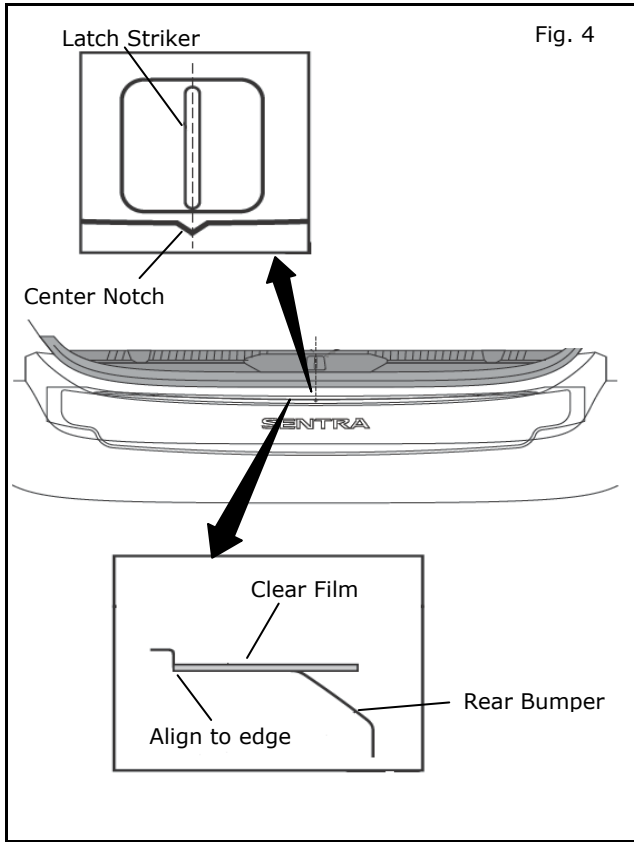

- 5) Align applique into position with notch to latch striker and film edge against bumper edge.

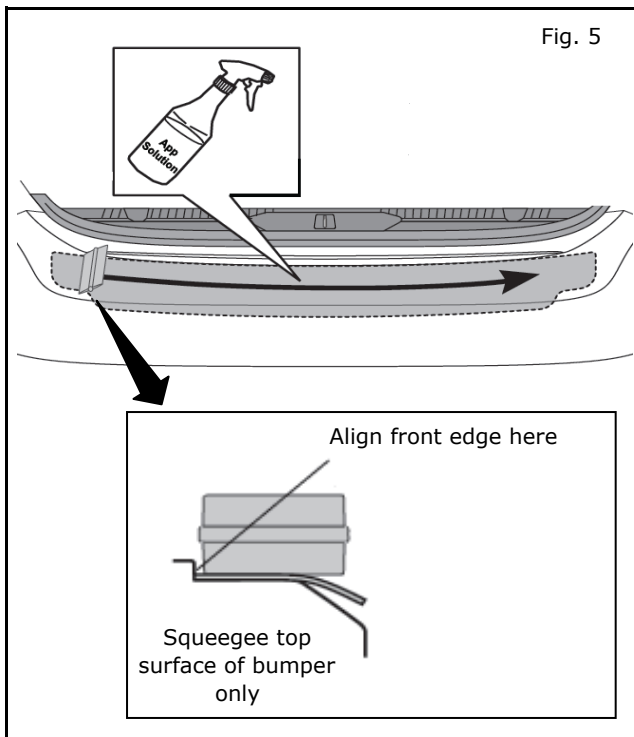

- 6) Spray top surface of pre-mask with even mist of application solution.
- 7) Begin squeegee while lightly touching pre-mask surface on top surface only.
- 8) As you drag squeegee apply firm pressure. This will aid in not leaving impression in part.
- 9) Firmly squeegee the applique down **ONLY** adhering on the top surface of the bumper.

INSTALLATION PROCEDURE: (continued)

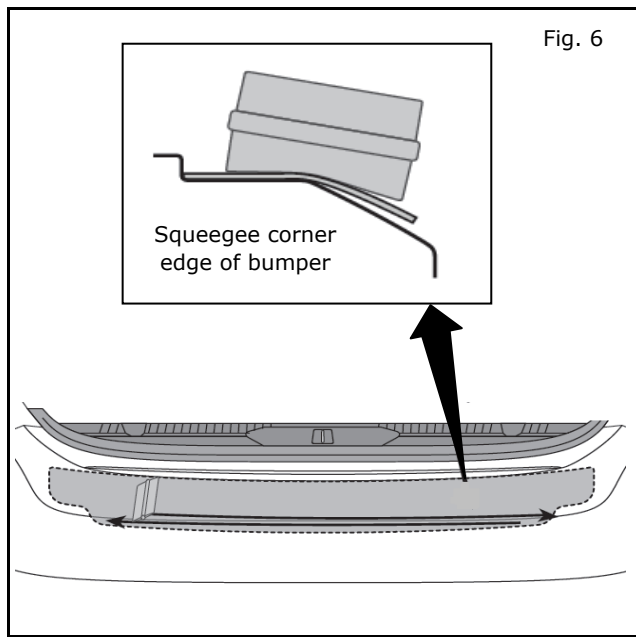

- 10) Firmly squeegee corner edge of bumper with three or four back and forth strokes in direction shown.

NOTE:

Make sure no bubbles are present before going to next step. Do not wrap edge at this time. Re-squeegee if bubbles are present.

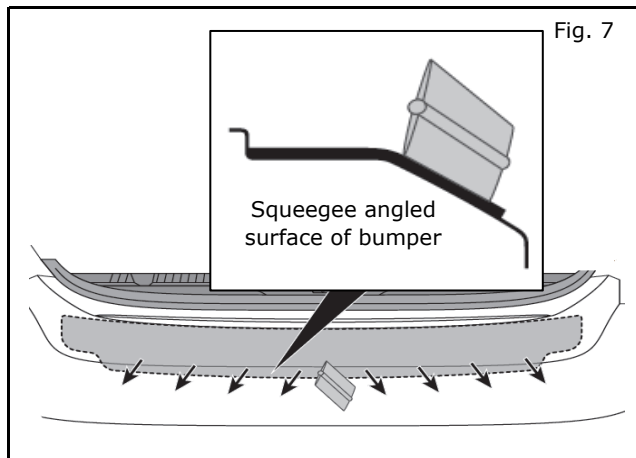

- 11) Adhere angled surface by holding squeegee at 45° angle and firmly squeegee from center to right with several strokes (repeat from center to left).
- 12) Make sure all air and water is removed from under applique. Re-squeegee any edges that may have lifted.

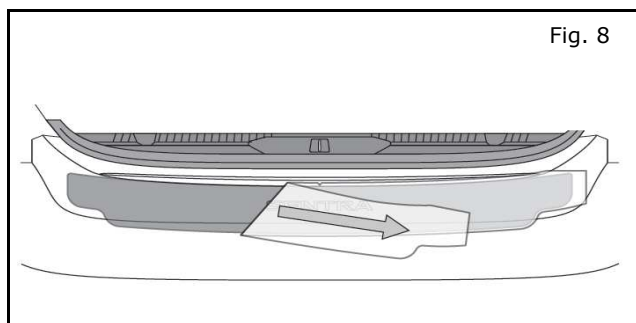

- 13) Remove pre-mask top protective covering CAREFULLY 180° against itself.
- 14) Re-squeegee any edges that may have lifted.

NOTE:

An alcohol & water solution can be sprayed under edges if not adhering.

NOTE:

Inspect for bubbles. If a bubble is located, re-squeegee using a firm, fast stroke. If the bubble persists, use air release tool to puncture the base of the bubble.

INSTALLATION PROCEDURE: (continued)

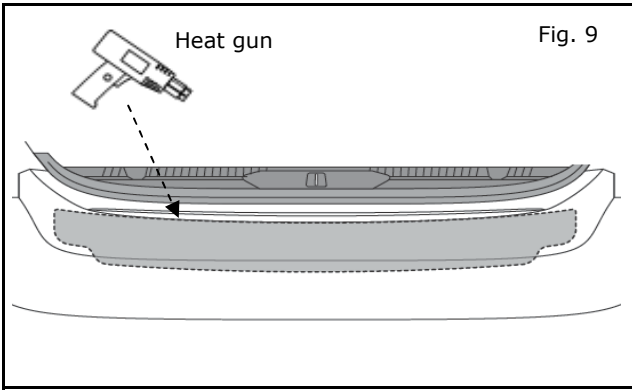

15) Use heat gun to secure edges.